

**Roca**

The logo graphic consists of a white, stylized wave or swoosh that starts under the 'R', dips down, and then rises to end under the 'a'. To the right of the end of the swoosh is a small, solid white rectangular block.

Product Care

Dear Customer,

Thank you for choosing Roca, we hope you will be very happy with your purchase. Roca, synonymous with design and quality, takes great care with the manufacture of its products.

This leaflet has been designed to help in all aspects of after care throughout our product range.

The guidance on the following pages will ensure that our product remains functional in the years to come.

All Roca products carry CE marking for declaration of performance. Further information can be found on the Roca website at [www.uk.roca.com](http://www.uk.roca.com)

## Contents

### Product care recommendations

2. Vitreous China
3. Seat Hinges
3. Electrical Components
3. Brassware and Chrome fittings
4. Acrylic products (including baths, shower trays, plastic seats and plastic bath panels)
4. Cast-Iron and Steel Baths
5. Furniture
6. Identifying cistern fittings
7. WC maintenance

### Type 1 fittings

7. WC maintenance
8. Removal of push button and diaphragm washer maintenance

### Type 2 fittings

9. Removal of push button
10. Maintenance procedure
11. Product range identification
12. Warranty periods
12. Contact details

## Vitreous China

### Do

- ✓ Clean regularly with warm soapy water (to stop the build up of dirt and limescale), rinse with cold water, dry and polish with a dry soft cloth.
- ✓ A cream or liquid cleaner can be used.
- ✓ Occasional use of mild bathroom limescale removers is acceptable if used in accordance with manufacturer's instructions, rinsing off immediately with plenty of cold water.
- ✓ Use of bleach in the toilet bowl is acceptable.
- ✓ A ceramic rubber can be used to remove metal marks and minor blemishes.
- ✓ In hard water areas we strongly recommend that **inhibitors** or **water softeners** are fitted to the system during installation to help prevent limescale attack.
- ✓ Do ensure that in hard water areas periodic checks are made to the diaphragm washer, located on the bottom of the flush valve.

### Don't

- ✗ Do not put bleach products (e.g. bleach blocks or tablets) in the actual cistern as this can damage the internal fittings and will invalidate the warranty on the internal parts.
- ✗ Do not put strong cleaners or bleach in the products to stand overnight.
- ✗ Do not mix different cleaners in the WC as they can cause a chemical reaction and give off poisonous gas.

## Seat Hinges

### Do

- ✓ Clean with warm soapy water.
- ✓ Rinse thoroughly and dry with a soft cloth.

### Don't

- ✗ Do not force the operation of a soft-close seat.
- ✗ Clean with abrasive materials or products containing bleach.

## Electrical Components

### Do

- ✓ Ensure that electrical components are fitted by a qualified electrician.
- ✓ Use a dry cloth to clean.

### Don't

- ✗ Do not clean electrical products while they are switched on.

## Brassware and Chrome fittings

### Do

- ✓ Clean immediately after use to stop a build up of dirt and limescale.
- ✓ Clean with warm water containing a few drops of washing-up liquid, rinse immediately and dry with a soft cloth.

### Don't

- ✗ Do not use products such as paint stripper, nail varnish remover, household bleach, perfume, after-shave and strong disinfectants, as chrome is vulnerable to acid attack. These may have a varying effect on the surface from black spots or streaks, which can't be removed, due to the corrosion of the surface.
- ✗ Do not scratch the finish as this can be a cause for corrosion.
- ✗ Clean with abrasive materials or products containing bleach.

## Acrylic products

(including baths, shower trays, plastic seats and plastic bath panels)

### Do

- ✓ Clean immediately after use to stop the build up of dirt and limescale.
- ✓ Use warm soapy water and rinse down with cold water, wiping down with any soft dry cloth.
- ✓ The use of a cream cleaner can be used if there is a build up of limescale.
- ✓ The occasional use of limescale removers is acceptable following manufacturers instructions, rinsing off with cold water immediately after use.
- ✓ Use T-Cut and a soft cloth to fix minor surface marks (acrylic baths only)

### Don't

- ✗ Do not use household chemicals or abrasive products such as hair dye, nail varnish remover, paint strippers, strong disinfectants, aftershave and household bleach.
- ✗ Some soap and shampoos can permanently discolour acrylic if allowed to pool undiluted for any length of time.
- ✗ Do not have lit cigarettes or naked flames near acrylic as it can burn and melt.

## Cast-Iron and Steel Baths

### Do

- ✓ Clean immediately after use to stop the build up of dirt and limescale.
- ✓ Use warm soapy water or mild detergent followed by rinsing and if desired drying with a soft dry cloth and this will be sufficient.
- ✓ Use a steel bath repair kit should any damage be caused to the bath. A Roca steel bath repair kit can be purchased through your local Roca outlet.

### Don't

- ✗ Do not use bleach or abrasive products when cleaning.
- ✗ Do not use bathroom limescale remover, mousse or any acidic or alkali cleaner, unless it has been specifically recommended in the manufacturers instructions as suitable for these type of products.
- ✗ Do not use steel wool or steel wool soap pads as these can leave rust spots.

## Furniture

### Do

- ✓ Clean furniture with a soft, clean and damp cloth, warm water and a mild household cleaner (such as diluted washing-up liquid).
- ✓ Any stainless steel parts should be cleaned with a soft, lint-free cloth and non-abrasive stainless steel cleaner. Spray directly on to the cloth and wipe clean.
- ✓ Ensure the bathroom is well ventilated to ensure the quality and appearance of the furniture is maintained.

### Don't

- ✗ Do not use abrasive cleaners or sharp objects when cleaning.
- ✗ Do not leave chemicals such as hair dye, nail-varnish remover or perfume on surfaces.
- ✗ Do not overload drawer units as this can damage the drawer runners.
- ✗ Do not leave water on the surface of the furniture, always wipe dry.

## Identifying cistern fittings

To identify which cistern fittings you have installed, please refer to the images below.

### Type 1 fittings

Inlet valve /  
Fill valve



Outlet valve /  
Drop valve /  
Flush valve



### Type 2 fittings

Inlet valve /  
Fill valve



Outlet valve /  
Drop valve /  
Flush valve



## WC maintenance

If water runs into your WC bowl for longer than five minutes after flushing please refer to the cistern maintenance procedure or read the following for further details:

- The float height on the inlet valve may have moved or been set too high thus causing water to internally overflow into the pan (contact the installer).
- There could be a build up of limescale or debris on the diaphragm washer (at the base of the outlet valve/drop valve/flush valve). See cistern maintenance for step by step instructions on how to change the diaphragm washer. As a temporary measure the original washer can be cleaned, reversed and refitted whilst waiting for a replacement washer.
- The pan and cistern could have been installed on an un-level surface causing the flush valve mechanism to foul against the side of the valve body. If this is the case the pan and cistern should be refitted according to the installation instructions.
- The installer may have used sealant or mastic which has chemically attacked the component part(s).
- Cleaning products such as bleach blocks may have been used which have chemically attacked the component part(s).
- The valves may be fouling against the internal walls of the cistern, or against one another.

## WC maintenance - Type 1 fittings

- The installation site could have low water pressure which prevents the inlet valve from closing off. The cistern therefore continually fills and overflows into the internal overflow.
- The black cross headed screw which holds the push button in place (see cistern maintenance) may have been over-tightened thus distorting the valve mechanism and preventing it from sealing
- The black securing nut which is located under the cistern base, may not have been tightened sufficiently.
- The push button rods may not be set to the correct height, check that the circular and crescent moon push buttons are aligned with the chrome shroud.



## How to remove a push button and maintain the diaphragm washer - Type 1 fittings

1. Turn off the water supply to the cistern and flush.
2. Close toilet seat and lid.
3. Press and hold down the circular push button.
4. Lift out the crescent moon push button.
5. Remove the circular push button.
6. Use a cross-headed screwdriver to remove the black plastic retaining grub screw.
7. Lift out the push button body.
8. The cistern lid can now be removed.
9. Expose the valve seal (diaphragm washer) by gripping the valve below the blue reduced flush float and turn the valve anti-clockwise to unlock (picture 1).
10. Using the rubber diaphragm washer as a grip, twist the white compression bayonet (see picture 2) and pull the washer, bayonet and support washer away from the rest of the valve.
11. Inspect the rubber diaphragm washer. Clean or replace as necessary.
12. Refitting the valve is reversal of removal taking care to locate the four tabs of the valve body into the four notches of the valve seat (pictures 3, 4 and 5).
13. Re-fitting the button is reversal of removal taking care to replace the buttons on the correct sides, ensure that the screw which holds the push button in place is not over-tightened.

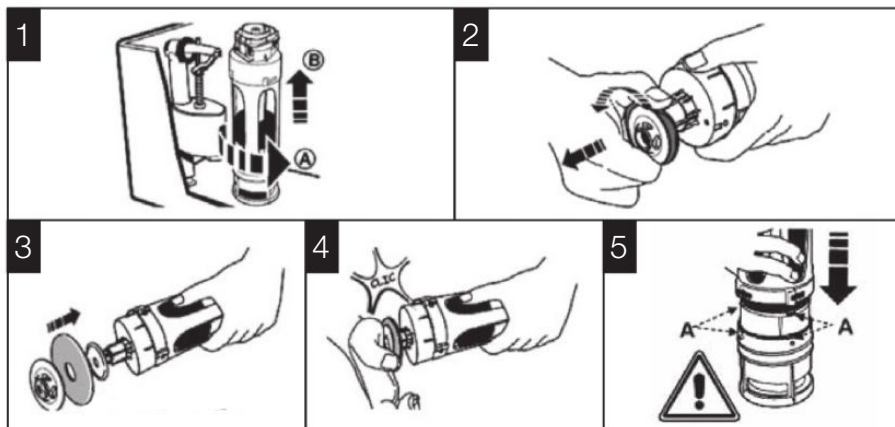
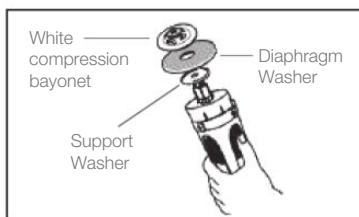

## How to remove a push button - Type 2 fittings

1. Lift the cistern lid upwards from the cistern.
2. Turn the cistern lid upside down to reveal the push button securing nut.
3. Unscrew the securing nut to remove the push button from the cistern lid.

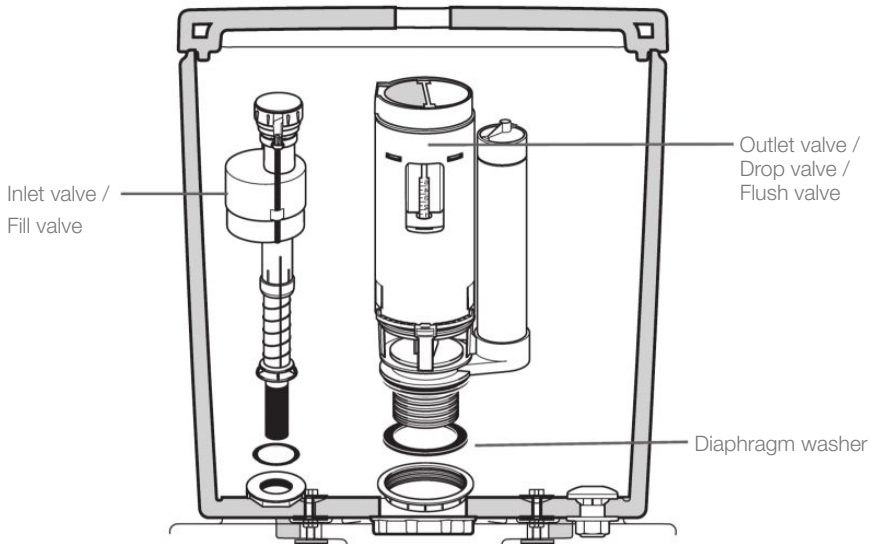
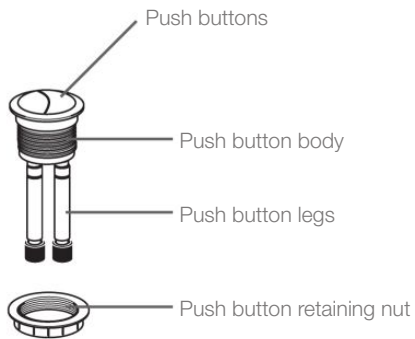

## Maintenance procedure - Type 2 fittings

1. Turn off water supply.
2. Remove lid.
3. Expose the diaphragm washer by twisting the valve until a sharp click then pull upwards.
4. Check the diaphragm seal is clean and no dirt is sitting on the face A.
5. If necessary remove diaphragm and turn over to provide clean seal face.
6. Replace the valve by pushing down and twisting the valve until it clicks.
7. Refer to assembly instructions for correct orientation and replace lid.
8. Check the push button orientation is correct. The full flush button should be in contact with the full flush paddle (grey paddle).

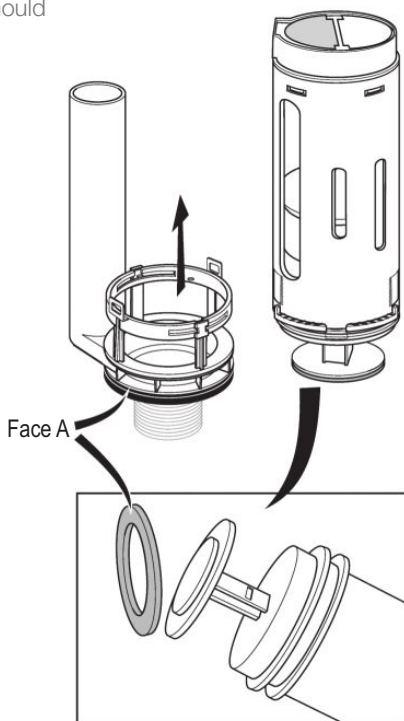
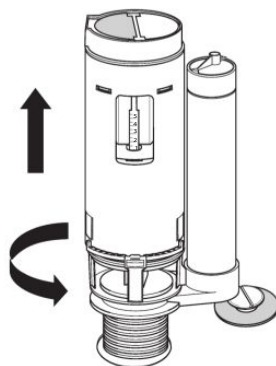

## Product range identification

The name of the product range may be written on the underneath of the WC seat. If this is not the case, it can be identified by a code imprinted on the underside of the cistern lid.

Code	Product Range	Code	Product Range
43580	Frontalis	88320	Dama (Lever)
88570	Element	43782	Dama-N
43650	Khroma	88510	Senso
88440	Veranda	88512	Senso Compact
88560	Happening	88460	Giralda
88490	New Classical	88470	The Gap
88410	Georgia	88730	The Gap Rimless (CleanRim)
88380	Sydney	NXTT1 / 46310	Nexo
88620	Hall	NXCT4 / 43612	Nexo Compact
88351	Meridian	88990	Debba
88240	Meridian-N	88396 / 88390	Laura
88240	Meridian-N Compact	88307	Laura (Lever)
88322	Dama (Push button)	88294	Polo

## Warranty

The Company warrants that all Goods purchased after 1st September 2008 will be free from defects for the following periods:

Ceramics	25 years	Mirrors and lights	2 years
Acrylic baths	25 years	Accessories	2 years
Steel baths	25 years	Bath panels	2 years
Cast Iron baths	25 years	Seats and covers	2 years
Enclosures and Screens	10 years	Concealed cisterns (including concealed cistern internals, excluding diaphragm washer)	5 years
Brassware and Showers (lifetime guarantee on ceramic cartridge)	5 years	Installation system frame	10 years
Furniture	2 years	Cistern Internals	1 year

## Contact details

For Customer Service and Aftersales assistance, please contact our offices.

### Roca Ltd.

Samson Road,  
Hermitage Ind. Estate,  
Coalville,  
Leicestershire  
LE67 3FP

Telephone: 01530 830 080

Fax: 01530 830 010

[www.uk.roca.com](http://www.uk.roca.com)

### Roca Ireland

Unit 628A,  
Jordanstown Avenue,  
Greenogue Industrial Estate,  
Rathcoole,  
County Dublin

Telephone: (01) 401 9340

## Notes



**Roca Ltd.**

Samson Road  
Hermitage Ind. Estate  
Coalville  
Leicestershire  
LE67 3FP

Tel: 01530 830 080  
Fax: 01530 830 010  
[www.uk.roca.com](http://www.uk.roca.com)

**Roca Ireland**

Unit 628A  
Jordanstown Avenue  
Greenogue Industrial Estate  
Rathcoole  
County Dublin

Tel: (01) 401 9340

V1 July 2015

**Roca**